

Introduction - Grade 5 Mathematics

The following released test questions are taken from the Grade 5 Mathematics Standards Test. This test is one of the California Standards Tests administered as part of the Standardized Testing and Reporting (STAR) Program under policies set by the State Board of Education.

All questions on the California Standards Tests are evaluated by committees of content experts, including teachers and administrators, to ensure their appropriateness for measuring the California academic content standards in Grade 5 Mathematics. In addition to content, all items are reviewed and approved to ensure their adherence to the principles of fairness and to ensure no bias exists with respect to characteristics such as gender, ethnicity, and language.

This document contains released test questions from the California Standards Test forms in 2003, 2004, 2005, 2006, 2007, and 2008. First on the pages that follow are lists of the standards assessed on the Grade 5 Mathematics Test. Next are released test questions. Following the questions is a table that gives the correct answer for each question, the content standard that each question is measuring, and the year each question last appeared on the test.

The following table lists each strand/reporting cluster, the number of items that appear on the exam, and the number of released test questions that appear in this document.

STRAND/REPORTING CLUSTER	NUMBER OF QUESTIONS ON EXAM	NUMBER OF RELEASED TEST QUESTIONS
Number Sense – Estimation, Percents, and Factoring	12	19
Number Sense – Operations with Fractions and Decimals	17	23
Algebra and Functions	17	25
Measurement and Geometry	15	23
Statistics, Data Analysis, and Probability	4	6
TOTAL	65	96

In selecting test questions for release, three criteria are used: (1) the questions adequately cover a selection of the academic content standards assessed on the Grade 5 Mathematics Test; (2) the questions demonstrate a range of difficulty; and (3) the questions present a variety of ways standards can be assessed. These released test questions do not reflect all of the ways the standards may be assessed. Released test questions will not appear on future tests.

For more information about the California Standards Tests, visit the California Department of Education's Web site at <http://www.cde.ca.gov/ta/tg/sr/resources.asp>.

THE NUMBER SENSE STRAND

In Grade 5, there are two reporting clusters within the Number Sense strand: 1) Estimation, Percents, and Factoring and 2) Operations with Fractions and Decimals. This booklet contains released test questions for each of these clusters.

The following five California content standards are included in the Estimation, Percents, and Factoring reporting cluster of the Number Sense strand and are represented in this booklet by 19 test questions. These questions represent only some ways in which these standards may be assessed on the Grade 5 California Mathematics Standards Test.

CALIFORNIA CONTENT STANDARDS IN THIS REPORTING CLUSTER

Number Sense

Standard Set 1.0	Students compute with very large and very small numbers, positive integers, decimals, and fractions and understand the relationship between decimals, fractions, and percents. They understand the relative magnitudes of numbers:
5NS1.1	Estimate, round, and manipulate very large (e.g., millions) and very small (e.g., thousandths) numbers.
5NS1.2*	Interpret percents as a part of a hundred; find decimal and percent equivalents for common fractions and explain why they represent the same value; compute a given percent of a whole number.
5NS1.3	Understand and compute positive integer powers of nonnegative integers; compute examples as repeated multiplication.
5NS1.4*	Determine the prime factors of all numbers through 50 and write the numbers as the product of their prime factors by using exponents to show multiples of a factor (e.g., $24 = 2 \times 2 \times 2 \times 3 = 2^3 \times 3$).
5NS1.5*	Identify and represent on a number line decimals, fractions, mixed numbers, and positive and negative integers.

* Denotes key standards (*Mathematics Framework for California Public Schools*)

The following five California content standards are included in the Operations with Fractions and Decimals reporting cluster of the Number Sense strand and are represented in this booklet by 23 test questions. These questions represent only some ways in which these standards may be assessed on the Grade 5 California Mathematics Standards Test.

CALIFORNIA CONTENT STANDARDS IN THIS REPORTING CLUSTER

Number Sense

Standard Set 2.0	Students perform calculations and solve problems involving addition, subtraction, and simple multiplication and division of fractions and decimals:
5NS2.1*	Add, subtract, multiply, and divide with decimals; add with negative integers; subtract positive integers from negative integers; and verify the reasonableness of the results.
5NS2.2*	Demonstrate proficiency with division, including division with positive decimals and long division with multidigit divisors.
5NS2.3*	Solve simple problems, including ones arising in concrete situations, involving the addition and subtraction of fractions and mixed numbers (like and unlike denominators of 20 or less), and express answers in the simplest form.
5NS2.4	Understand the concept of multiplication and division of fractions.
5NS2.5	Compute and perform simple multiplication and division of fractions and apply these procedures to solving problems.

* Denotes key standards (*Mathematics Framework for California Public Schools*)

THE ALGEBRA AND FUNCTIONS STRAND/REPORTING CLUSTER

The following five California content standards are included in the Algebra and Functions strand/reporting cluster and are represented in this booklet by 25 test questions. These questions represent only some ways in which these standards may be assessed on the Grade 5 California Mathematics Standards Test.

CALIFORNIA CONTENT STANDARDS IN THIS STRAND/CLUSTER

Algebra and Functions

Standard Set 1.0	Students use variables in simple expressions, compute the value of the expression for specific values of the variable, and plot and interpret the results:
5AF1.1	Use information taken from a graph or equation to answer questions about a problem situation.
5AF1.2*	Use a letter to represent an unknown number; write and evaluate simple algebraic expressions in one variable by substitution.
5AF1.3	Know and use the distributive property in equations and expressions with variables.
5AF1.4*	Identify and graph ordered pairs in the four quadrants of the coordinate plane.
5AF1.5*	Solve problems involving linear functions with integer values; write the equation; and graph the resulting ordered pairs of integers on a grid.

* Denotes key standards (*Mathematics Framework for California Public Schools*)

THE MEASUREMENT AND GEOMETRY STRAND/REPORTING CLUSTER

The following seven California content standards are included in the Measurement and Geometry strand/reporting cluster and are represented in this booklet by 23 test questions. These questions represent only some ways in which these standards may be assessed on the Grade 5 California Mathematics Standards Test.

CALIFORNIA CONTENT STANDARDS IN THIS STRAND/CLUSTER

Measurement and Geometry	
Standard Set 1.0	Students understand and compute the volumes and areas of simple objects:
5MG1.1*	Derive and use the formula for the area of a triangle and of a parallelogram by comparing it with the formula for the area of a rectangle (i.e., two of the same triangles make a parallelogram with twice the area; a parallelogram is compared with a rectangle of the same area by cutting and pasting a right triangle on the parallelogram).
5MG1.2*	Construct a cube and rectangular box from two-dimensional patterns and use these patterns to compute the surface area for these objects.
5MG1.3*	Understand the concept of volume and use the appropriate units in common measuring systems (i.e., cubic centimeter [cm ³], cubic meter [m ³], cubic inch [in ³], cubic yard [yd ³]) to compute the volume of rectangular solids.
5MG1.4	Differentiate between, and use appropriate units of measures for, two- and three-dimensional objects (i.e., find perimeter, area, volume).
Standard Set 2.0	Students identify, describe, and classify the properties of, and the relationships between, plane and solid geometric figures:
5MG2.1*	Measure, identify, and draw angles, perpendicular and parallel lines, rectangles, and triangles by using appropriate tools (e.g., straightedge, ruler, compass, protractor, drawing software).
5MG2.2*	Know that the sum of the angles of any triangle is 180° and the sum of the angles of any quadrilateral is 360° and use this information to solve problems.
5MG2.3	Visualize and draw two-dimensional views of three-dimensional objects made from rectangular solids.

* Denotes key standards (*Mathematics Framework for California Public Schools*)

THE STATISTICS, DATA ANALYSIS, AND PROBABILITY STRAND/REPORTING CLUSTER

The following five California content standards are included in the Statistics, Data Analysis, and Probability strand/reporting cluster and are represented in this booklet by six test questions. These questions represent only some ways in which these standards may be assessed on the Grade 5 California Mathematics Standards Test.

CALIFORNIA CONTENT STANDARDS IN THIS STRAND/CLUSTER

Statistics, Data Analysis, and Probability

Standard Set 1.0 Students display, analyze, compare, and interpret different data sets, including data sets of different sizes:

5PS1.1 Know the concepts of mean, median, and mode; compute and compare simple examples to show that they may differ.

5PS1.2 Organize and display single-variable data in appropriate graphs and representations (e.g., histogram, circle graphs) and explain which types of graphs are appropriate for various data sets.

5PS1.3 Use fractions and percentages to compare data sets of different sizes.

5PS1.4* Identify ordered pairs of data from a graph and interpret the meaning of the data in terms of the situation depicted by the graph.

5PS1.5* Know how to write ordered pairs correctly; for example, (x, y) .

* Denotes key standards (*Mathematics Framework for California Public Schools*)

Released Test Questions

Math

5

1 What is 6050.287 rounded to the nearest ten?

- A 6050
- B 6100
- C 6050.29
- D 6050.3

CSM01224

2 The total land area for the United States is 3,537,438 square miles. What is this value rounded to the nearest thousand square miles?

- A 3,500,000
- B 3,537,000
- C 3,538,000
- D 3,540,000

CSM20973

3 What is 40% of 250?

- A 50
- B 100
- C 150
- D 200

CSM01275

4 What is $\frac{3}{8}$ written as a percent?

- A 26.7%
- B 30%
- C 37.5%
- D 50%

CSM10512

5 What is the decimal 0.7 written as a fraction?

- A $\frac{1}{7}$
- B $\frac{3}{4}$
- C $\frac{3}{7}$
- D $\frac{7}{10}$

CSM01687

6 A company donated 200 books to a local library. If 70 of them are fiction, what percent of the donated books are fiction?

- A 35%
- B 40%
- C 60%
- D 65%

CSM20545

7 In a parking lot, 1 out of every 8 cars is blue. What percent of the cars in this lot are blue?

- A 1.25%
- B 7%
- C 9%
- D 12.5%

CSM10520

8 What decimal is equal to $\frac{3}{5}$?

- A 0.30
- B 0.35
- C 0.60
- D 1.67

CSM20271

9 What is 50% of 40?

- A 2000
- B 200
- C 20
- D 2

CSM02004

10 $5^3 =$

- A $5 \times 5 \times 5$
- B $5 + 5 + 5$
- C $3 \times 3 \times 3 \times 3 \times 3$
- D $3 + 3 + 3 + 3 + 3$

CSM00219

11 What is the prime factorization of 45?

- A $2^3 \times 5$
- B $3^2 \times 5$
- C $5^2 \times 3$
- D $5^2 \times 9$

CSM01258

12 What is the prime factorization of 12?

- A $2^2 \times 3$
- B $2^2 \times 3^2$
- C 4×3
- D 1×2

CSM11022

13 What is the prime factorization of 36?

- A $2^2 \times 3^2$
- B $2^2 \times 3^3$
- C 4×3^2
- D 4×9

CSM11027

14 Which of the following shows the number 60 factored into prime numbers?

- A 2×30
- B 3×20
- C $2 \times 3 \times 10$
- D $2 \times 2 \times 3 \times 5$

CSM01726

15 Which expression shows the prime factorization of 48?

- A 6×8
- B $2 \times 4 \times 6$
- C $2 \times 2 \times 2 \times 6$
- D $2 \times 2 \times 2 \times 2 \times 3$

CSM11158

Released Test Questions

Math



16 What are all of the different prime factors of 36?

- A 3
- B 7
- C 2 and 3
- D 3 and 7

CSM20991

17



Which letter on the number line *best* identifies the location of -6 ?

- A P
- B Q
- C R
- D S

CSM02265

18 Which point on the number line *best* represents 1.35?

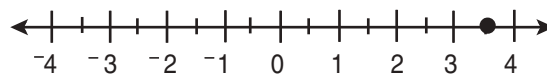

A

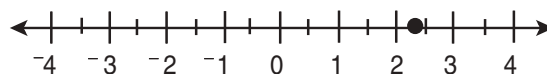

B

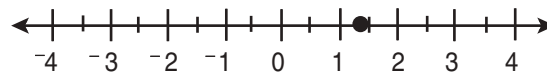

C

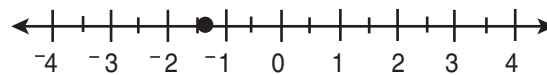

D

CSM11065

19 Which number line appears to show the dot placed at $\frac{1}{5}$?

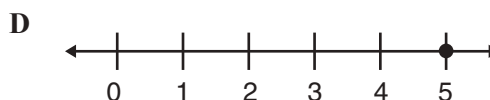
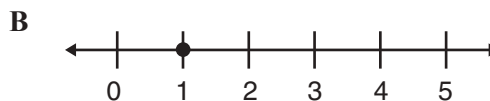
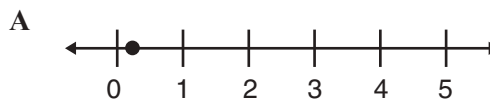

CSM20882

20

$11.3 \times 2.7 =$

- A 29.31
- B 29.51
- C 30.31
- D 30.51

CSM02247

21

Javier bought 9 pounds of ground beef. He saved \$8.37 by using a store coupon. How much did he save per pound of ground beef?

- A \$0.89
- B \$0.93
- C \$1.08
- D \$75.33

CSM11157

22

Veronica can type 28 words per minute. At this rate, how many words can Veronica type in 5.5 minutes?

- A 154
- B 157
- C 159
- D 162

CSM10756

23

Tony had a rope 8.35 meters long. He cut off 2.6 meters. How long was the piece of rope that was left?

- A 5.65 meters
- B 5.75 meters
- C 6.65 meters
- D 6.75 meters

CSM00221

24

$$\begin{array}{r} 39.06 \\ \times 0.3 \\ \hline \end{array}$$

- A 9.708
- B 9.718
- C 11.608
- D 11.718

CSM11156

25

Robert wants to buy 3 notebooks that cost \$1.25 each. How much do the notebooks cost all together, without tax?

- A \$1.28
- B \$2.40
- C \$3.75
- D \$4.25

CSM20831

26

Maria has \$7.50 to buy lunch. If she buys a turkey sandwich that costs \$2.75, how much money will she have left?

- A \$4.75
- B \$5.25
- C \$5.75
- D \$10.25

CSM20834

27

$$\begin{array}{r} 7.2 \\ \times 3.3 \\ \hline \end{array}$$

- A 23.76
- B 24.86
- C 237.6
- D 248.6

CSM02007

Released Test Questions

Math

5

28 $15.12 \div 2.4 =$

- A 0.513
- B 0.63
- C 5.13
- D 6.3

CSM02031

29 $35,705 \div 37 =$

- A 89
- B 843
- C 925
- D 965

CSM01263

30 At a school, there are 704 desks to place into 22 classrooms. If the same number of desks is placed in each classroom, how many desks will be in each room?

- A 32
- B 34
- C 42
- D 44

CSM21094

31 What is the answer to this division problem?

$$12 \overline{)246}$$

- A 2.05
- B 2.5
- C 20.5
- D 25

CSM02020

32 Maurice talked on the telephone to two friends. He talked to Sherry for $\frac{1}{4}$ hour, and to Gabriel for $\frac{1}{3}$ hour. How much time did Maurice spend on the telephone?

- A $\frac{1}{6}$ hour
- B $\frac{2}{7}$ hour
- C $\frac{5}{12}$ hour
- D $\frac{7}{12}$ hour

CSM02011

33 $2\frac{1}{3} + 4\frac{1}{2} =$

- A $6\frac{1}{6}$
- B $6\frac{1}{5}$
- C $6\frac{2}{5}$
- D $6\frac{5}{6}$

CSM11147

- 34** It takes Suzanne $\frac{1}{6}$ hour to walk to the playground and $\frac{1}{3}$ hour to walk from the playground to school. How much time does it take Suzanne to walk to the playground and then to school?

- A $\frac{2}{9}$ hour
 B $\frac{1}{3}$ hour
 C $\frac{1}{2}$ hour
 D $\frac{2}{3}$ hour

CSM20960

35 $4\frac{3}{4} - 2\frac{1}{2} =$

- A $1\frac{1}{4}$
 B $1\frac{3}{4}$
 C $2\frac{1}{4}$
 D $2\frac{3}{4}$

CSM02013

- 36** Hector can throw a ball $50\frac{3}{5}$ feet. Lee can throw the same ball $48\frac{1}{3}$ feet. How much farther can Hector throw the ball than Lee?

- A $2\frac{2}{15}$ feet
 B $2\frac{4}{15}$ feet
 C $2\frac{3}{5}$ feet
 D $2\frac{4}{5}$ feet

CSM20953

- 37** Yoshi spent $1\frac{1}{3}$ hours reading and $\frac{3}{4}$ hour doing chores. How many total hours did Yoshi spend on these activities?

- A $1\frac{1}{3}$
 B $1\frac{4}{7}$
 C $2\frac{1}{12}$
 D $2\frac{1}{6}$

CSM20954

Released Test Questions

Math

5

38

$$\frac{3}{4} \div \frac{3}{5} =$$

- A $\frac{9}{20}$
- B $\frac{4}{5}$
- C $1\frac{1}{4}$
- D $2\frac{2}{9}$

CSM00753

39

$$12 \div \frac{3}{4} =$$

- A 9
- B $9\frac{1}{4}$
- C $12\frac{3}{4}$
- D 16

CSM11154

40 What is the denominator when $\frac{5}{6}$ is multiplied by $\frac{7}{8}$?

- A 35
- B 40
- C 42
- D 48

CSM20964

41

$$\frac{1}{5} \cdot \frac{1}{6} =$$

- A $\frac{1}{11}$
- B $\frac{2}{11}$
- C $\frac{1}{30}$
- D $\frac{2}{30}$

CSM01729

42

John runs $\frac{8}{10}$ mile every day. How many miles does he run in 30 days?

- A 18
- B 24
- C 30
- D 38

CSM30506

43

$$c + 2\frac{1}{2}$$

Which situation could be described by the expression above?

- A Lia jogged c miles yesterday, and $2\frac{1}{2}$ miles farther today.
- B Lia jogged c miles yesterday, and $2\frac{1}{2}$ miles fewer today.
- C Lia jogged $2\frac{1}{2}$ miles yesterday, and c miles fewer today.
- D Lia jogged $2\frac{1}{2}$ miles yesterday, and c times as far today.

CSM00715

- 44 The table below shows the average number of lunches bought in a cafeteria each day over a period of years.

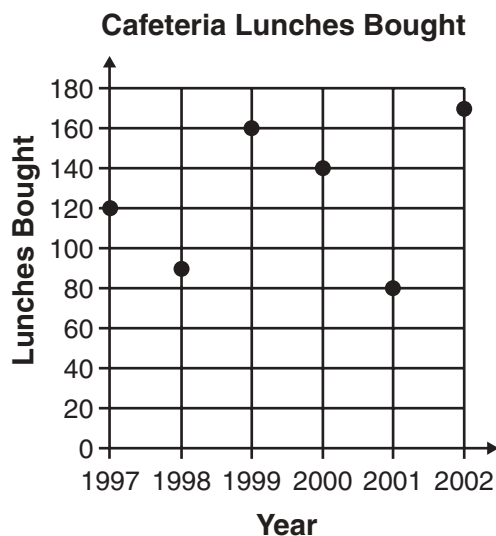

The greatest decrease in the number of lunches bought occurred between which two years?

- A from 1998 to 1999
 B from 1999 to 2000
 C from 2000 to 2001
 D from 2001 to 2002
- 45 If $N = 4$, what is the value of $6 \times N - 3$?

- A 6
 B 9
 C 18
 D 21

- 46 If $k = 6$, what is the value of $7k - 2$?

- A 30
 B 40
 C 54
 D 65

CSM11096

- 47 If $n = 31$, what is the value of $6 - n$?

- A -37
 B -25
 C 25
 D 37

CSM00225

- 48 Which expression represents the product of n and 25?

- A $25n$
 B $25 - n$
 C $25 + n$
 D $25 \div n$

CSM21225

- 49 If $z = 3$, what is $5 \times (6 - z)$?

- A 10
 B 15
 C 27
 D 53

CSM11106

CSM21192

CSM02010

Released Test Questions

Math

5

50 Sophie caught twice as many fish as her dad. If her dad caught F fish, how many fish did Sophie catch?

- A $F + 2$
- B $F - 2$
- C $F \times 2$
- D $F \div 2$

CSM01719

51 Ahn has 64 crayons. This number is 18 more crayons than Bill has. Which equation should be used to find b , the number of crayons Bill has?

- A $b = 64 - 18$
- B $b = \frac{64}{18}$
- C $b = 64 + 18$
- D $b = 64 \times 18$

CSM11113

52 If $s = 4$, what is the value of $s(9 - 4)$?

- A 16
- B 20
- C 32
- D 45

CSM11109

53 Bill played a game and scored 5 times. If each time Bill scored he earned p points, which expression represents the total number of points that Bill scored?

- A $p + 5$
- B $p - 5$
- C $p \times 5$
- D $p \div 5$

CSM20974

54 What value for z makes this equation true?

$$8 \times 37 = (8 \times 30) + (8 \times z)$$

- A 7
- B 8
- C 30
- D 37

CSM02040

55 What value for w makes this equation true?

$$5 \times w = (5 \times 20) + (5 \times 3)$$

- A 3
- B 20
- C 23
- D 203

CSM00743

56 What value of p makes this equation true?

$$44 \times 73 = 44 \times (p + 3)$$

- A 41
- B 47
- C 70
- D 73

CSM40019

57 The map below shows the starting positions of two scientists studying plants in a rain forest.

Scientists in Rain Forest

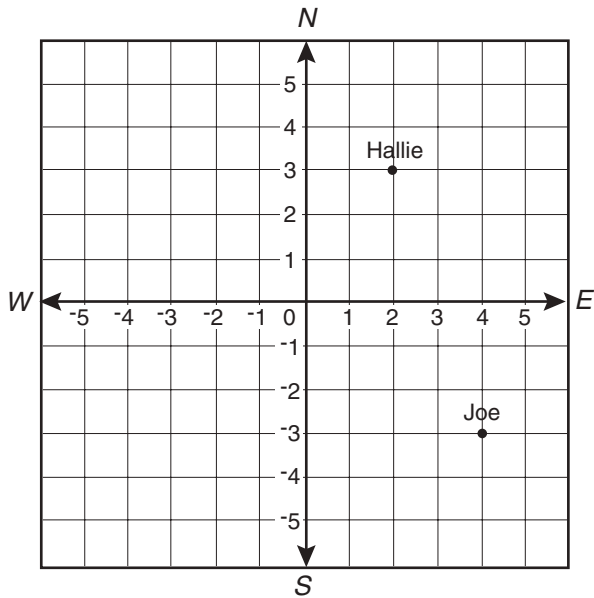

Which ordered pair *best* names Joe's location?

- A (3, -4)
- B (-3, 4)
- C (4, -3)
- D (-4, 3)

CSM02036

58 The map below shows the location of 4 different stores.

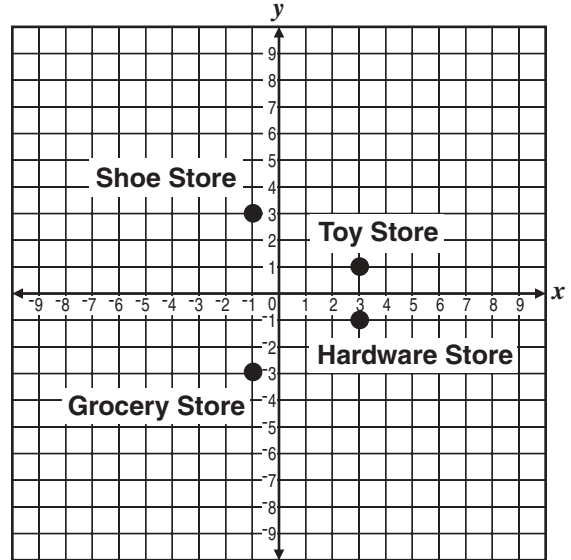

Which store is at the point (3, -1)?

- A Hardware Store
- B Grocery Store
- C Shoe Store
- D Toy Store

CSM11115

59 The map below shows the locations of rides at an amusement park. Maria was at the point $(-1, -4)$.

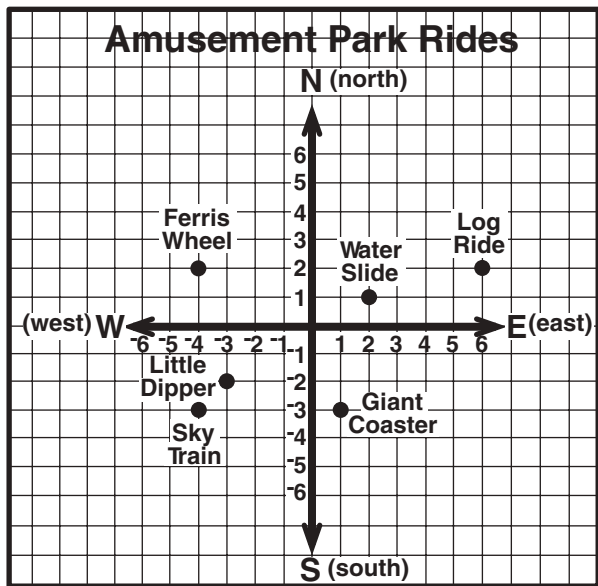

She walked 2 units west and 2 units north. Which ride did she walk to?

- A Giant Coaster
- B Little Dipper
- C Sky Train
- D Ferris Wheel

CSM02025

60 What is the ordered pair for point B ?

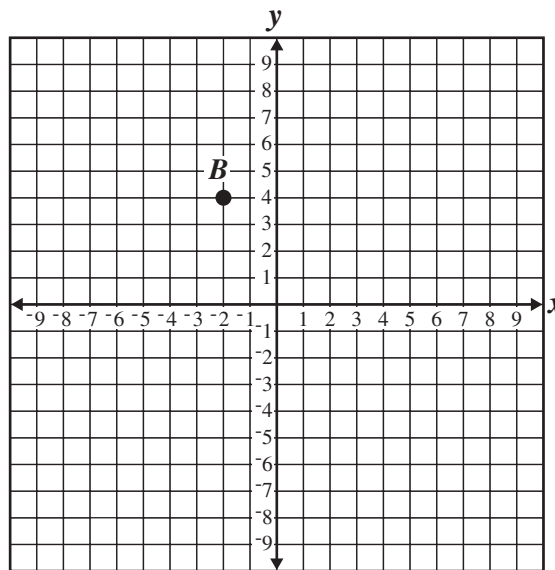

- A $(-4, 2)$
- B $(-2, 4)$
- C $(2, -4)$
- D $(2, 4)$

CSM10393

61 This coordinate grid shows the location of 4 tents around a campfire.

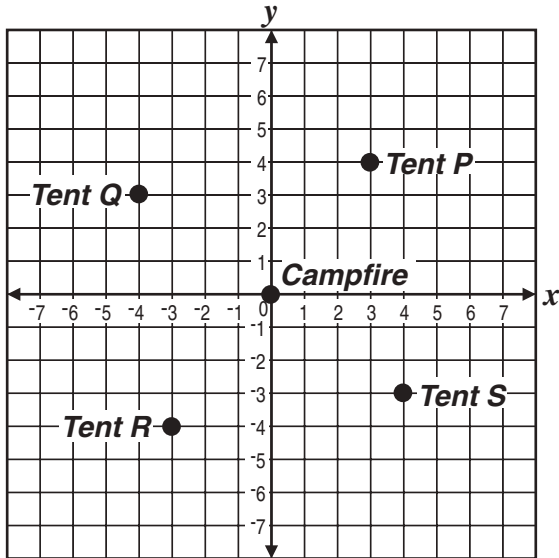

Which tent is located at point $(-4, 3)$?

- A Tent P
- B Tent Q
- C Tent R
- D Tent S

CSM20534

62 Which point represents $(3, -6)$?

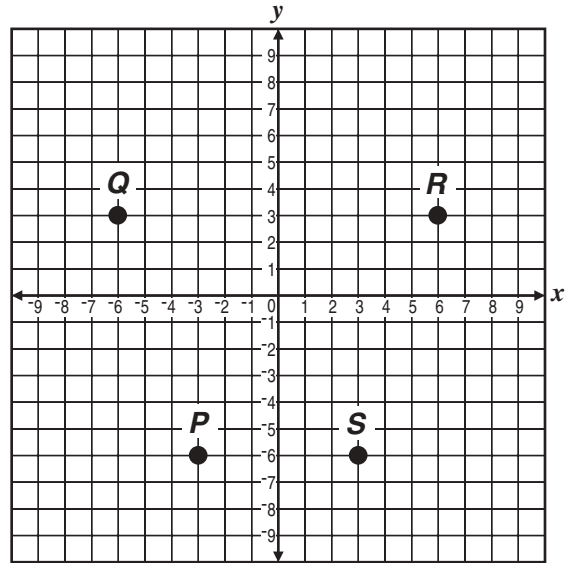

- A point P
- B point Q
- C point R
- D point S

CSM11117

Released Test Questions

Math

5

- 63 Which equation could have been used to create this function table?

x	y
-9	-5
-2	2
4	8
11	15

- A $y = \frac{x}{2}$
- B $y = 2x$
- C $y = x - 4$
- D $y = x + 4$

CSM01204

- 64 Line m is represented by the equation $y = 4$.

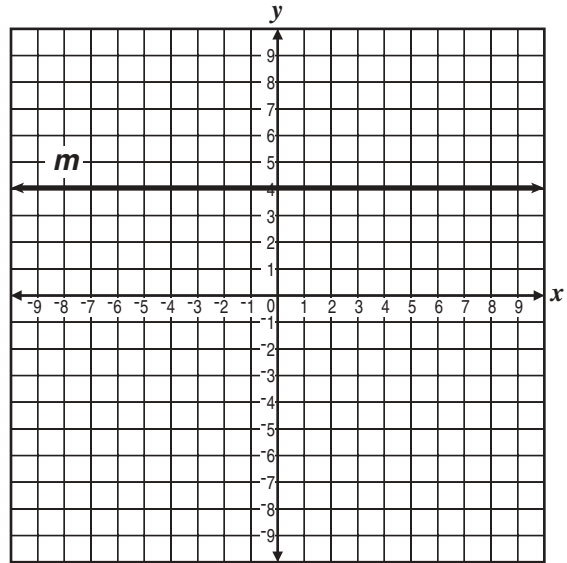

Which ordered pair is located on line m ?

- A (1, 4)
- B (0, 0)
- C (4, 1)
- D (4, 0)

CSM10934

- 65 Which table represents values of x and y such that $y = x + 5$?

A

x	y
-1	4
0	5

B

x	y
-1	-6
0	-5

C

x	y
2	5
5	0

D

x	y
2	3
3	0

CSM11121

- 66 Which equation shows the relationship of all the values in the table below?

x	y
-2	-6
-1	-3
0	0
1	3
2	6

- A $y = 3x$
 B $x = y + 3$
 C $y = x + 3$
 D $x = 3y$

CSM11120

- 67 Joaquin charges \$4.00 per hour to baby-sit. What equation could Joaquin use to find the number of hours (h) he needs to baby-sit in order to earn \$50.00?

- A $4h = 50$
 B $\frac{h}{4} = 50$
 C $h - 4 = 50$
 D $4 + h = 50$

CSM21381

- 68 In the figure below, $WXYZ$ is a parallelogram.

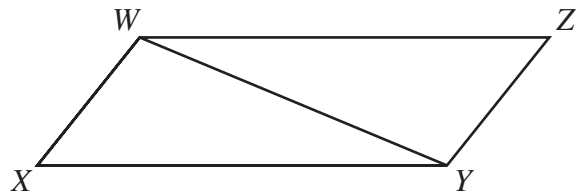

If the area of triangle WXY is 22 square inches, what is the area of $WXYZ$?

- A 11 square inches
 B 22 square inches
 C 33 square inches
 D 44 square inches

CSM01750

Released Test Questions

Math



- 69 In this parallelogram, triangle A has an area of 37 square feet.

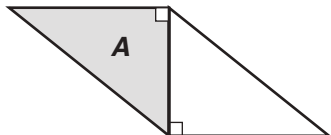

What is the area, in square feet, of the parallelogram?

- A 18.5
- B 37
- C 55.5
- D 74

CSM10326

- 71 What is the area, in square meters, of the parallelogram below?

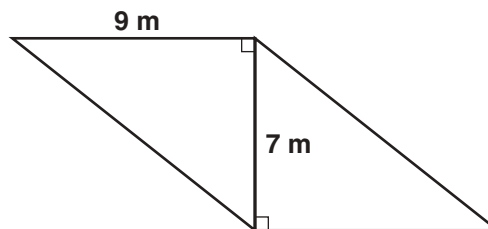

- A 31.5
- B 54
- C 63
- D 70.6

CSM10329

- 70 The trapezoid below can be divided into 3 identical triangles.

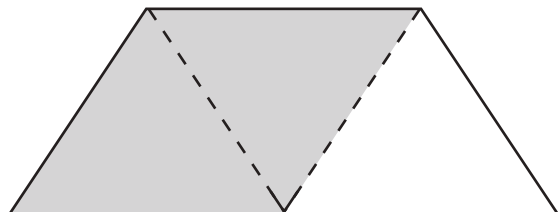

If the area of the shaded parallelogram is 16 cm^2 , what is the area of the trapezoid?

- A 8 cm^2
- B 24 cm^2
- C 32 cm^2
- D 48 cm^2

CSM20550

- 72 Triangles A and B are congruent.

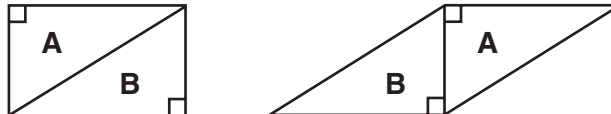

If the area of the rectangle is 7 square units, what is the area, in square units, of the parallelogram?

- A 3.5
- B 7
- C 14
- D 18.5

CSM30245

- 73 What is the surface area of the box formed by the pattern below?

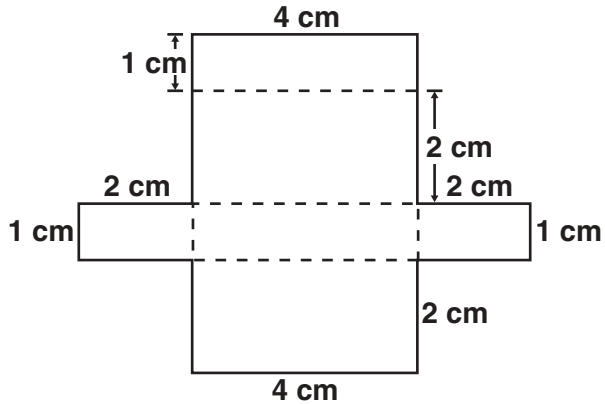

- A 28 cm^2
 B 24 cm^2
 C 14 cm^2
 D 8 cm^2

CSM10941

74

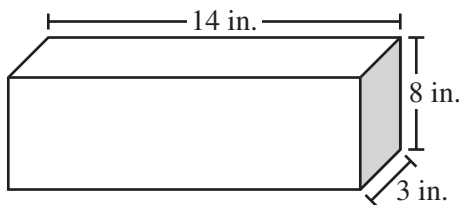

This rectangular prism has a length of 14 inches, a height of 8 inches, and a width of 3 inches. What is the volume?

- A 25 cu in.
 B 42 cu in.
 C 112 cu in.
 D 336 cu in.

CSM02273

- 75 What is the volume, in cubic inches, of the school locker below?

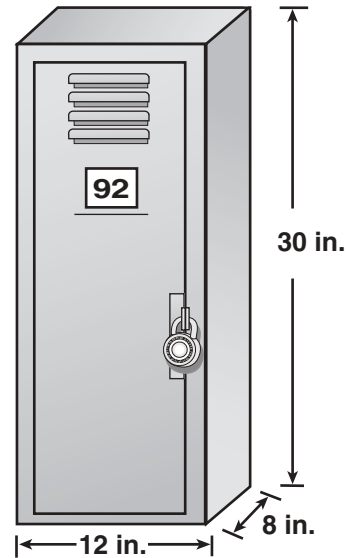

- A 2880
 B 2580
 C 390
 D 360

CSM10332

- 76 What is the volume of a cube that measures 10 inches on each edge?

- A 10 cubic inches
 B 100 cubic inches
 C 1000 cubic inches
 D 10,000 cubic inches

CSM00232

Released Test Questions

Math



77 What is the volume, in cubic yards, of the storage unit below?

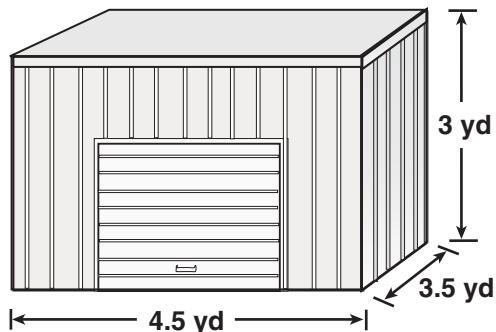

- A 11
- B 24
- C 40.5
- D 47.25

CSM10341

78 A store has a rectangular parking lot that is 100 feet by 120 feet. What is the perimeter of the parking lot?

- A 220 feet
- B 440 feet
- C 1200 square feet
- D 12,000 square feet

CSM21284

79 The area of a backyard would *most likely* be measured in

- A square inches.
- B cubic inches.
- C cubic feet.
- D square feet.

CSM11123

80 Which is *closest* to the measure of the angle shown below?

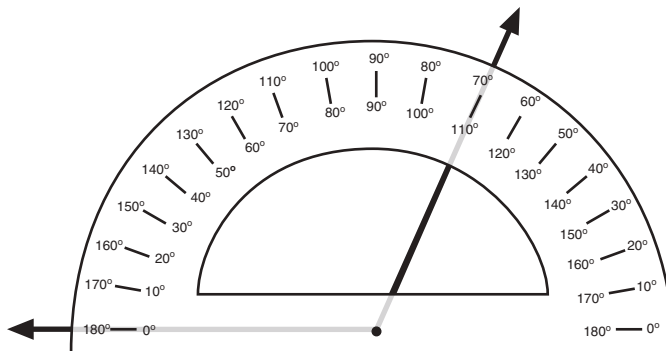

- A 70°
- B 80°
- C 100°
- D 110°

CSM01234

81 Which of the following *best* describes the figure below?

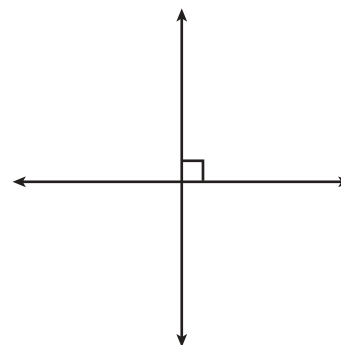

- A acute angles
- B obtuse angles
- C parallel lines
- D perpendicular lines

CSM21238

- 82 What is the approximate measure of this angle in degrees?

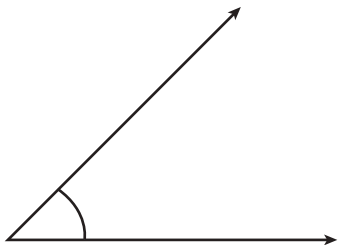

- A 20°
 B 45°
 C 110°
 D 135°

CSM21197

- 83 Use your ruler to answer the question below.



What is the perimeter of the rectangle in centimeters?

- A 3
 B 5
 C 8
 D 16

CSM10554

- 84

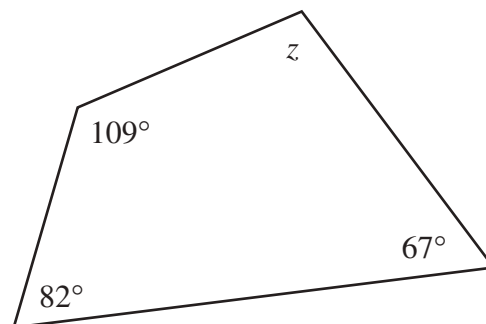

What is the measure of angle z in the figure above?

- A 12°
 B 102°
 C 122°
 D 180°

CSM01264

- 85

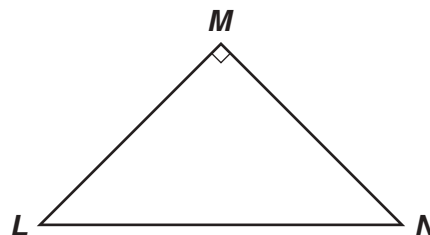

Triangle LMN is a right triangle, and angles L and N are equal. What is the measure of angle L ?

- A 25°
 B 45°
 C 70°
 D 90°

CSM10346

Released Test Questions

Math

5

- 86** Nina made a triangle by cutting the corner off a sheet of paper.

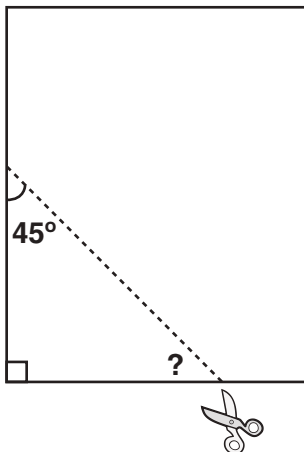

One angle is 45° . What is the measure of the third angle of Nina's triangle?

- A 30°
- B 45°
- C 55°
- D 60°

CSM21243

- 87** Andrew constructed a triangle so that $\angle 1$ and $\angle 2$ were the same size and $\angle 3$ measured 80° .

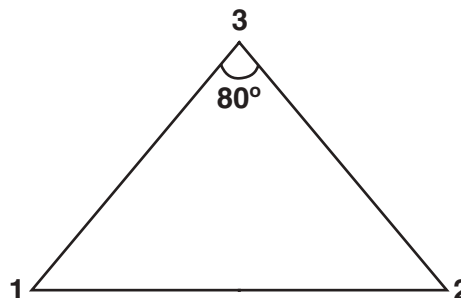

What is the measure of $\angle 1$?

- A 50°
- B 60°
- C 80°
- D 100°

CSM21239

- 88** What is the measure of angle R ?

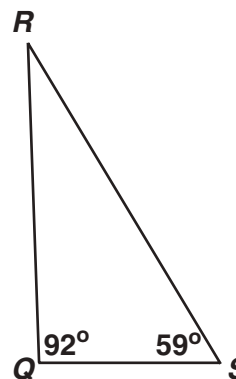

- A 17°
- B 29°
- C 31°
- D 39°

CSM10344

89 The measures of three interior angles in a quadrilateral are 35° , 50° , and 125° . What is the degree measure of the fourth interior angle?



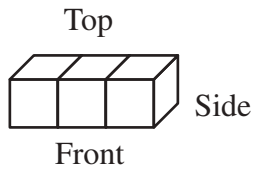

- A 60°
- B 90°
- C 120°
- D 150°

CSM11130

90 The figure below is made of 3 small cubes.



Which *best* shows the side view of the figure?

- A 
- B 
- C 
- D 

CSM02033

91 Sharice scored the following numbers of points in 5 dart games.

88, 96, 112, 135, 144

What is the median of these numbers?

- A 56
- B 88
- C 112
- D 115

CSN00266

92 Students were asked how they traveled to school each day. The table below shows these results.

Travel to School

Type of Travel	Percentage
Bus	50%
Car	30%
Walk	15%
Bike	5%

Which graphic correctly displays these data?

A

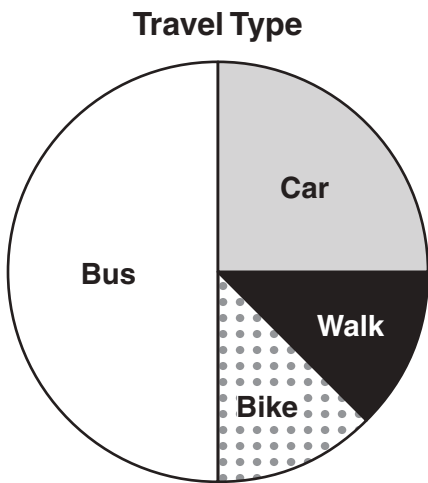

C

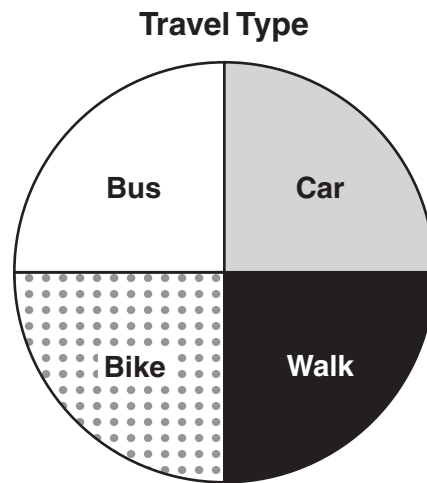

B

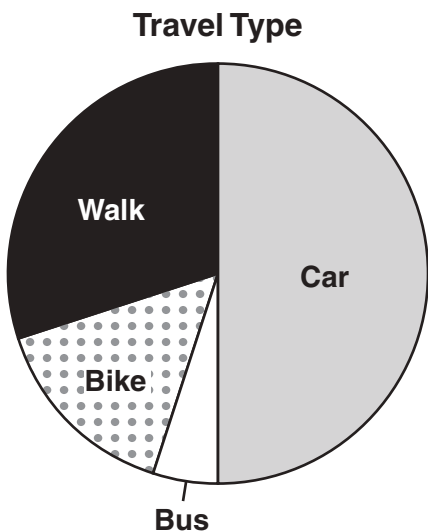

D

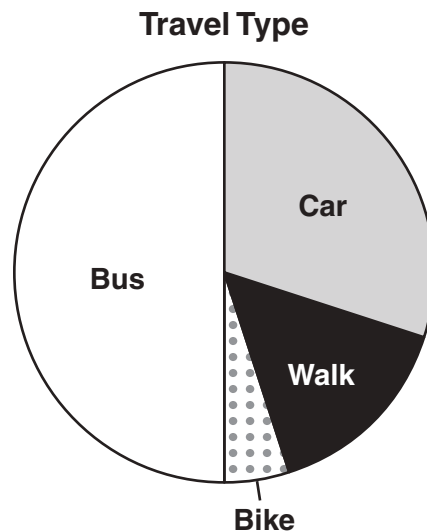

- 93 A group of people went fishing for four days. Together, they caught 20 pounds of fish each day.

Day 1

Fish	Part of Total Pounds
Tuna	$\frac{5}{20}$
Snapper	$\frac{3}{20}$
Flounder	$\frac{8}{20}$
Mackerel	$\frac{4}{20}$

Day 3

Fish	Part of Total Pounds
Tuna	$\frac{6}{20}$
Snapper	$\frac{6}{20}$
Flounder	$\frac{5}{20}$
Mackerel	$\frac{3}{20}$

Day 2

Fish	Part of Total Pounds
Tuna	$\frac{10}{20}$
Snapper	$\frac{1}{20}$
Flounder	$\frac{4}{20}$
Mackerel	$\frac{5}{20}$

Day 4

Fish	Part of Total Pounds
Tuna	$\frac{4}{20}$
Snapper	$\frac{5}{20}$
Flounder	$\frac{3}{20}$
Mackerel	$\frac{8}{20}$

On which day was tuna 50% of the total catch?

- A Day 1
- B Day 2
- C Day 3
- D Day 4

Released Test Questions

Math



94 Regina’s piano teacher kept this record of Regina’s progress on a song she is memorizing.

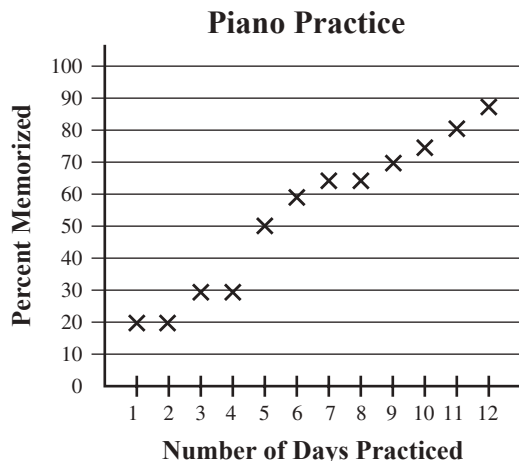

How many days of practice did it take for Regina to memorize half of the song?

- A 4
- B 5
- C 6
- D 8

CSN00180

95 The graph shows the high temperature on 5 days in July.

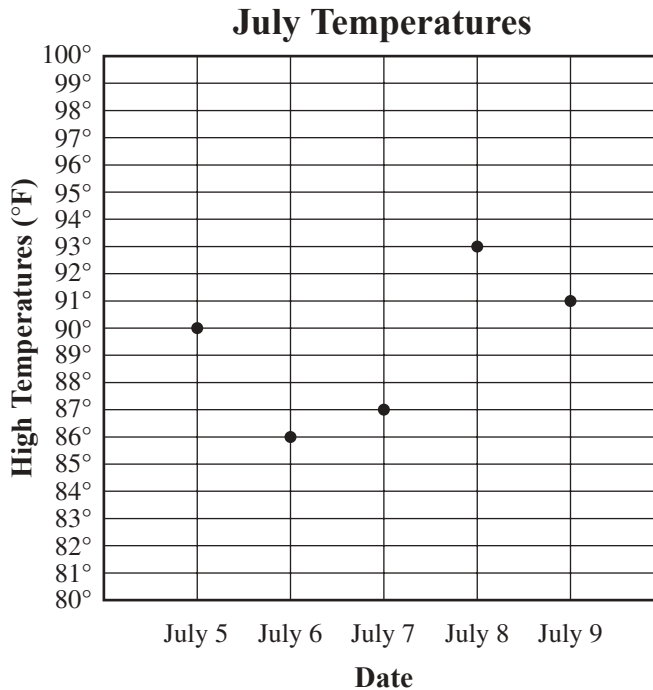

What was the high temperature on July 7?

- A 86°F
- B 87°F
- C 88°F
- D 89°F

CSN00306

96 Which point represents $(5, 2)$ on this graph?

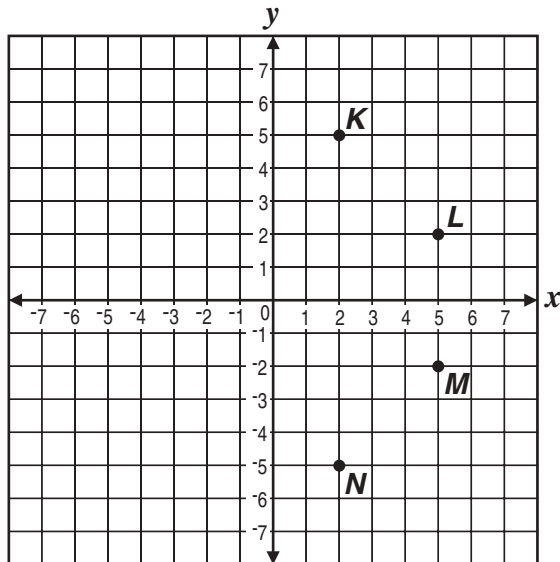

- A point K
- B point L
- C point M
- D point N

CSM21199

Released Test Questions

Math

5

Question Number	Correct Answer	Standard	Year of Release
1	A	5NS1.1	2004
2	B	5NS1.1	2005
3	B	5NS1.2	2003
4	C	5NS1.2	2004
5	D	5NS1.2	2005
6	A	5NS1.2	2005
7	D	5NS1.2	2006
8	C	5NS1.2	2007
9	C	5NS1.2	2008
10	A	5NS1.3	2003
11	B	5NS1.4	2003
12	A	5NS1.4	2004
13	A	5NS1.4	2006
14	D	5NS1.4	2007
15	D	5NS1.4	2008
16	C	5NS1.4	2008
17	A	5NS1.5	2003
18	C	5NS1.5	2004
19	A	5NS1.5	2007
20	D	5NS2.1	2003
21	B	5NS2.1	2004
22	A	5NS2.1	2005
23	B	5NS2.1	2005
24	D	5NS2.1	2005
25	C	5NS2.1	2007
26	A	5NS2.1	2007
27	A	5NS2.1	2008
28	D	5NS2.2	2003
29	D	5NS2.2	2004
30	A	5NS2.2	2006
31	C	5NS2.2	2007
32	D	5NS2.3	2003
33	D	5NS2.3	2004
34	C	5NS2.3	2005
35	C	5NS2.3	2005

Question Number	Correct Answer	Standard	Year of Release
36	<i>B</i>	5NS2.3	2006
37	<i>C</i>	5NS2.3	2008
38	<i>C</i>	5NS2.4	2003
39	<i>D</i>	5NS2.4	2007
40	<i>D</i>	5NS2.4	2008
41	<i>C</i>	5NS2.5	2004
42	<i>B</i>	5NS2.5	2008
43	<i>A</i>	5AF1.1	2004
44	<i>C</i>	5AF1.1	2007
45	<i>D</i>	5AF1.2	2003
46	<i>B</i>	5AF1.2	2004
47	<i>B</i>	5AF1.2	2005
48	<i>A</i>	5AF1.2	2005
49	<i>B</i>	5AF1.2	2006
50	<i>C</i>	5AF1.2	2006
51	<i>A</i>	5AF1.2	2007
52	<i>B</i>	5AF1.2	2008
53	<i>C</i>	5AF1.2	2008
54	<i>A</i>	5AF1.3	2003
55	<i>C</i>	5AF1.3	2007
56	<i>C</i>	5AF1.3	2008
57	<i>C</i>	5AF1.4	2003
58	<i>A</i>	5AF1.4	2004
59	<i>B</i>	5AF1.4	2006
60	<i>B</i>	5AF1.4	2006
61	<i>B</i>	5AF1.4	2008
62	<i>D</i>	5AF1.4	2007
63	<i>D</i>	5AF1.5	2003
64	<i>A</i>	5AF1.5	2004
65	<i>A</i>	5AF1.5	2005
66	<i>A</i>	5AF1.5	2005
67	<i>A</i>	5AF1.5	2006
68	<i>D</i>	5MG1.1	2003
69	<i>D</i>	5MG1.1	2006
70	<i>B</i>	5MG1.1	2007

Released Test Questions

Math

5

Question Number	Correct Answer	Standard	Year of Release
71	<i>C</i>	5MG1.1	2007
72	<i>B</i>	5MG1.1	2008
73	<i>A</i>	5MG1.2	2004
74	<i>D</i>	5MG1.3	2003
75	<i>A</i>	5MG1.3	2006
76	<i>C</i>	5MG1.3	2006
77	<i>D</i>	5MG1.3	2008
78	<i>B</i>	5MG1.4	2006
79	<i>D</i>	5MG1.4	2007
80	<i>D</i>	5MG2.1	2004
81	<i>D</i>	5MG2.1	2005
82	<i>B</i>	5MG2.1	2005
83	<i>D</i>	5MG2.1	2008
84	<i>B</i>	5MG2.2	2003
85	<i>B</i>	5MG2.2	2004
86	<i>B</i>	5MG2.2	2005
87	<i>A</i>	5MG2.2	2006
88	<i>B</i>	5MG2.2	2007
89	<i>D</i>	5MG2.2	2008
90	<i>A</i>	5MG2.3	2006
91	<i>C</i>	5PS1.1	2004
92	<i>D</i>	5PS1.2	2006
93	<i>B</i>	5PS1.3	2007
94	<i>B</i>	5PS1.4	2003
95	<i>B</i>	5PS1.4	2008
96	<i>B</i>	5PS1.5	2005